

S21 COMPOSITE DOOR

Seaglaze's NEW lightweight door has been designed around our existing Series 21 weathertight door, and enhanced to give an average saving of 7kg per door over our aluminium equivalent.

This is available in both a clamp-in and through-fixed aluminium frame depending on the superstructure thickness.

Working in partnership with CTruk to provide weight saving solutions, we are now able to offer the door leaf panel as a GRP composite with a RTM (Resin Transfer Moulding) core. This not only makes the door lighter but maintains the superior quality and durability that the Seaglaze brand is known for.

The frames are anodised and then powder coat painted in-house to a RAL colour of your choice, the panel is currently only available in RAL 9016 White.

KEY POINTS:

- Through Fix or Clamp In Frame
- Outward opening
- 110mm Radius
- Panel Only in RAL 9016
- Frame available in variety of finishes
- Keyed locks as standard

NEW FOR 2019



**4Kg lighter per m²
than Aluminium!**

See Reverse for Technical Data

S21 Clamp In Frame

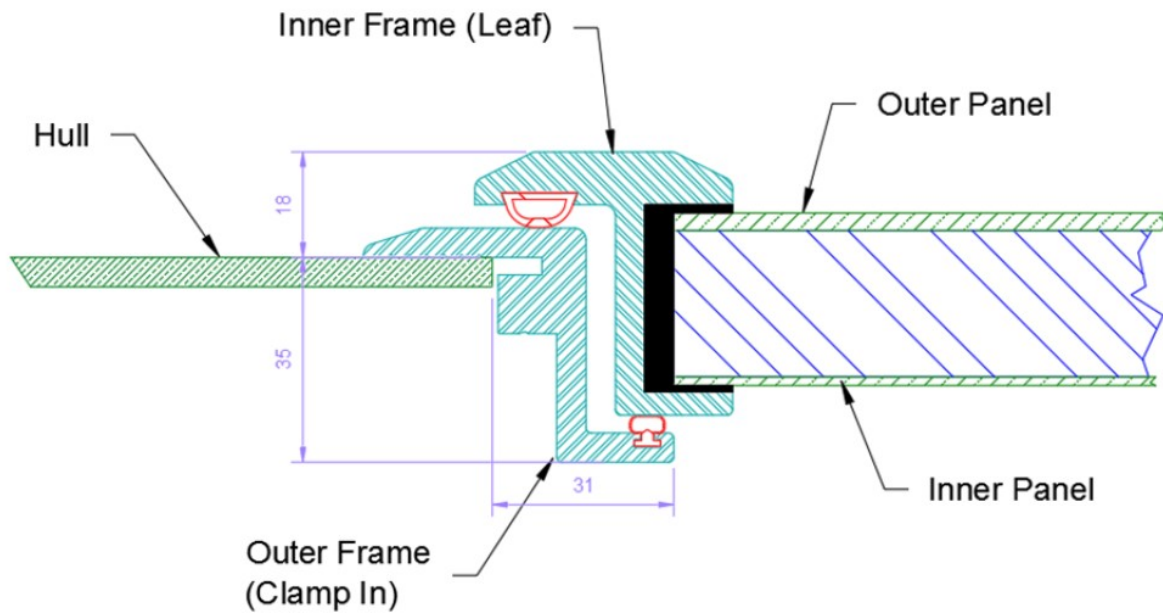

S21 Through Fix Frame

